

# P O T T E R Y B A R N

## Anna Daybed

### *Pre-assembly:*

- Please read all instructions carefully before assembly.
- For your safety and ease, assembly by three people is recommended.
- Save all packing materials until assembly is complete to avoid accidentally discarding small parts or hardware.

### *Parts Included:*

- BOX 1:
  - (1) Headboard
- BOX 2:
  - (1) Footboard
- BOX 3:
  - (1) Front side rail
  - (1) Back side rail
  - (1) Cross-slat roll
  
- (1) Hardware included:
  - (28) 8x30mm Phillips wood screws (A)

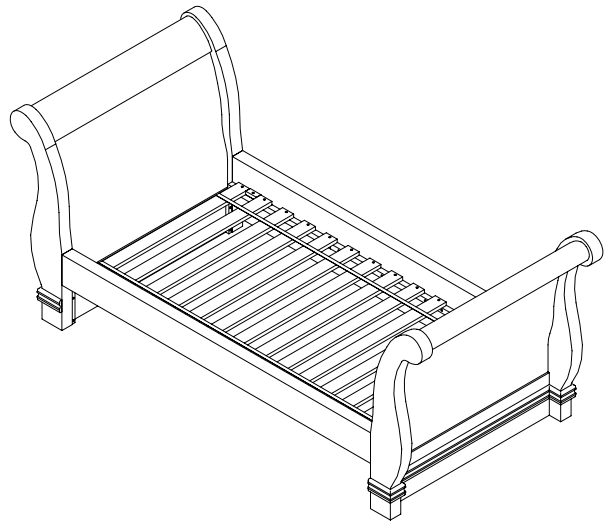

### *Tools Needed:*

- Phillips screwdriver (not provided) 

### *Assembly Instructions:*

1. One person should hold the headboard in a vertical position tilted slightly forward.
2. Attach the front side rail (small) and the back side rail (large) to the headboard by dropping the rails' hooked ends into the corresponding slots in the headboard. Be sure the lips of the front side rail and back side rail are facing inward.
3. Repeat the process with the footboard.

### *Mattress Support System Assembly Instructions:*

1. Place cross-slat roll on side rail lips and roll out so the pre-drilled hole on the end of each slat lines up with the pre-drilled holes on the side rail lips. (Binding should be face down).
2. Attach the cross-slats in place by inserting the 28 Phillips wood screws and tightening with Phillips screwdriver.
3. Periodically tighten all connections.

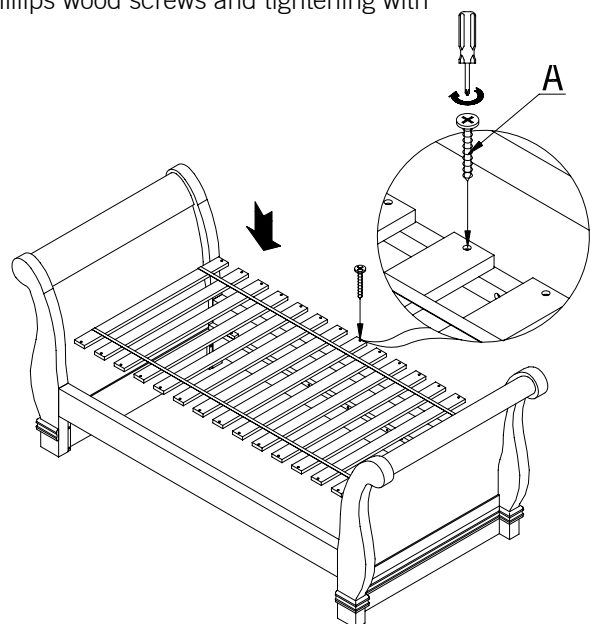
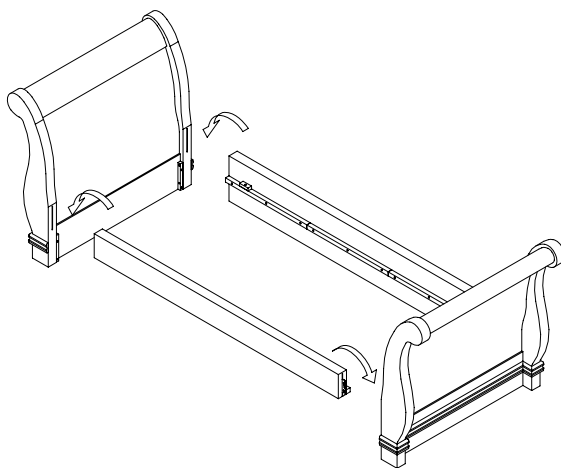

### *Care Instructions:*

- Dust with a clean, soft cloth. Avoid the use of all abrasive cleaners.